

DK-06-SSL-BPD219

This keder profile is designed for 219,1 mm diameter tube substructures. It fits snugly onto the tube and allows for a low overall height and an elegant appearance. 3dtex offers these profiles for all standard tube diameters, with only the base profile differing.

3dtex GmbH has further developed this keder profile for ETFE cushion constructions, which combines various functions in a compact design. It is equipped with an internal condensation channel that also acts as a secondary sealing level. The profile system has a thermal break, which reduces energy loss in heated buildings. The base profile is screwed directly to the substructure using self-drilling and self-tapping screws. The result is an aesthetically pleasing, compact design that differs significantly from the usual construction with individual brackets. The system allows even complex geometries to be reliably sealed against heavy rainfall. Installation is quick and easy. Sophisticated installation tools can be provided.

- for 6mm keder
- efficient fastening on the substructure with self-drilling and self-tapping screws from EJOT
- base, middle, keder and cover profile made of anodised aluminium 6063 T66
- incl. protective and sealing profile made of UV-resistant EPDM 70 Shore A
- incl. second sealing level to absorb any condensation or minor leaks, made of self-adhesive laminated EPDM, easy to install even in complex corners
- complex joint geometries possible
- incl. thermal separation with polycarbonate spacer sleeves
- incl. connecting pins for precise alignment of the profiles
- optional bird defense system

Cross-section with pipe connection Ø 219 mm

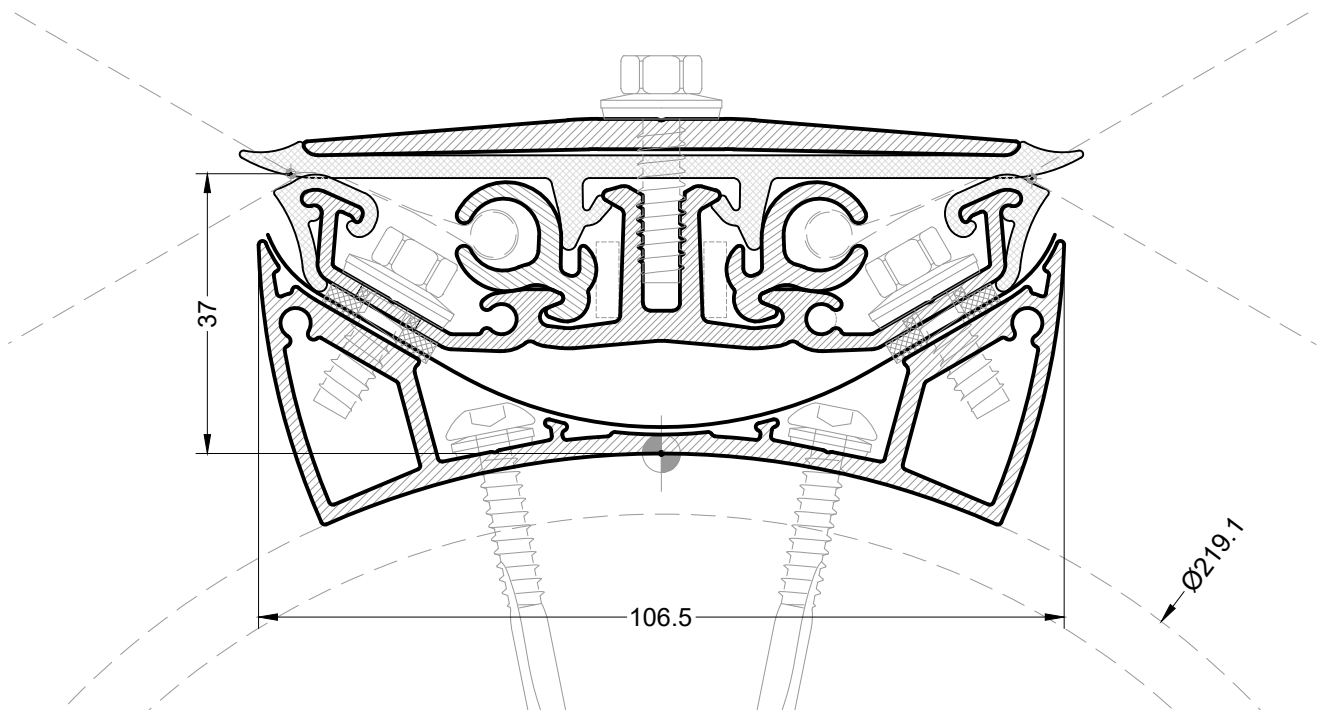

DK-06-SSL-BPD219

Structural elements with pipe connection \varnothing 219 mm

